

Concert Club VC Series

Front-of-House, Flyable



C115VA



C112VA



These Club VC Series models are fit to fly and ideal for installations.

- Solid, reliable connection hardware for suspended installation.
- Painsstaking selection of parts and components, optimized wooden enclosures, and a thorough reevaluation of speaker capacity take sonic performance to a new level.
- Dual phone jacks and dual Speakon connectors for input and parallel connection.
- Protection circuit prevents excessive tweeter input due to acoustic feedback or other causes.
- Durable exterior with spray finish, foamed steel grilles, and large metal handles for improved handling.
- The YSProcessing (Yamaha Speaker Processing) switch provided on the EMX series powered mixers and P series amplifiers enhances matching for even greater sonic impact.

OPTIONS (C112VA ONLY)

BCS251
Ceiling Bracket

BBS251
Baton Bracket

BWS251-300/400
Wall Bracket

Concert Club VC Series

GENERAL SPECIFICATIONS

	C112VA	C115VA
Type	2-way bass-reflex	
Frequency range (-10dB)	60Hz-16kHz	55Hz-16kHz
Nominal coverage	90H x 40V	
Nominal impedance	8Ω	
Power rating	NOISE	250W
	PGM	500W
	MAX	1000W
sensitivity (1W,1m)	97dB SPL	99dB SPL
Component	LF	12" cone
	HF	Horn + 2" voice coil driver
Connectors	Barrier strip	
Dimensions (W x H x D)	416 x 620 x 329mm (16.4" x 24.4" x 13.0")	485 x 715 x 373mm (19.1" x 28.1" x 14.7")
Weight	21.8kg (48.1lbs)	29.9kg (65.9lbs)
Accessories	3/8" Eyebolt x4, W5/16" screw x4 for 251 series brackets	3/8" Eyebolt x4

DIMENSIONS

unit : mm

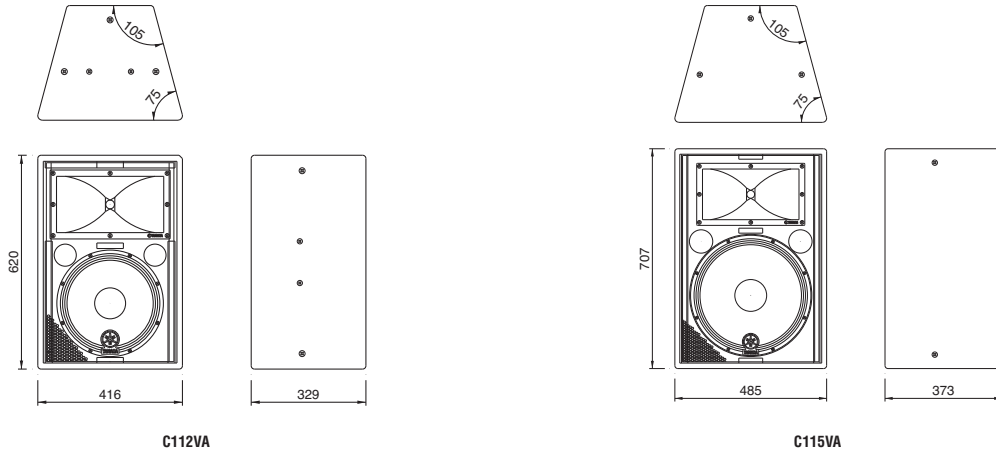

C112VA

C115VA